



METS ENERGY S A L

Model	MP9-S		MP11@6-2-S			
Frequency/Speed - Voltage	50HZ/1500 RPM- 230/400V		60HZ/1800 RPM- 230V/400V		60HZ/1800 RPM- 277V/480V	
Prime Power	9 KVA	7.2 KW	11 KVA	8.8 KW	11 KVA	8.8 KW
Standby Power	9.9 KVA	7.92 KW	12.1 KVA	9.68 KW	12.1 KVA	9.68 KW



Image for illustration purposes only.

Features

Engine	Perkins , 403-11G1 , Made in UK , in accordance to ISO3046 ,ISO8528,DIN6271
Alternator	Stamford PI044E , Made in UK, complying to the norms: BS EN60034/ BS 5000/ VDE 0530/ NEMA MG 1-32/ IEC 34/ CSA C22.2-100/ AS 1359
Control Panel	Deep sea, M-DCM-317 ,Made in UK, complying to the norms: comply to the norms BS EN 61000, BS EN 60950, BS EN 60068
Base Frame	Black steel with Anti-vibration pads, Built in fuel tank
Sound Proof Canopy	Modular SPC, Powder Coated, Extremely Durable, Designed to Reduce Sound Level with Maximum Service Accessibility and Minimum Foot Prints
Worldwide Support	Mets Energy Products are distributed through its PowerMets International Network For more information kindly check our website www.metsenergy.com

Rating Definitions and Conditions

Prime Rating	The power available for an unlimited hour usage with an average load factor of 80% of the published prime power over each 24 hours period. A 10 % overload is available for 1Hr every 12 hours.
Standby Rating	The power limited to 500 hours annual usage with an average load factor of 80% of the published standby power rating over each 24-hour period. Up to 300 hours of annual usage may be run continuously. No overload is permitted on standby power.

Due to continuous product development, we reserve the right to change specifications at any time without prior notice.

Rev0_MP9-S/MP11@6-2-S_150217



Engine Perkins, 403-11G1, 4 Stroke Cycle, Diesel

Structure	Number of Cylinders	3	
	Engine Build	In line	
	Bore	77 mm	
	Stroke	81 mm	
	Displacement	1.131 L	
	Compression Ratio	23/1	
	Aspiration	Natural	
	Cooling	Water cooled	
Fuel	Fuel Tank	1500 RPM Built in fuel tank 27 L for 9 hours operation @ full load	1800 RPM Built in fuel tank 27 L for 8.5 hours operation @ full load
	Fuel System	Direct injection	
	Fuel Recommended	N°2 Diesel	
	Fuel System Make (ECM)	-	
		1500 rpm	1800 rpm
	Delivery Flow Rate (l/hr)		
	Fuel Consumption		
	100% Load (g/kWh-L/hr)	248 (3)	248 (3.1)
	75% Load (g/kWh-L/hr)	257 (2.3)	257 (2.4)
	50% Load (g/kWh-L/hr)	280 (1.7)	280 (1.8)
Cooling system	Engine Coolant Capacity	5.2L	
	Air Flow-Radiator	TBA	TBA
	radiator with 50 degree ambient Cooling Package & Air Cleaner Kit Thermostatically-controlled		
Air Inlet	Air Intake Engine (Clean Filter/Dirty)	TBA	
Exhaust System	Exhaust Gas Temperature	445 °C	TBA
	Exhaust Gas Flow (Prime)	45 l/s	TBA
	Maximum Exhaust System Back Pressure	10.2 kPa	TBA
	Muffler	residential (20→25 dB)	industrial(15→25 dB)
	Stainless Steel exhaust flex-		
DC System-Starting/Charging	Cranking Battery Voltage	12 V	
	Battery Charging Alternator	15 A	
Heat Rejection(prime)	Radiated Heat to Ambient	3.2 KW	TBA
	Heat Rejection to Coolant	11.6 KW	TBA
	Heat Rejection to Exhaust	9.3 KW	TBA
	Heat Rejection to intercooler	None	TBA
Lube System	Lubricating System Oil Capacity	4.9 L	
Governor	Mechanical		

Due to continuous product development, we reserve the right to change specifications at any time without prior notice.
 Rev0_MP9-S/MP11@6-2-S_150217



METS ENERGY

Alternator Stamford , PI044E

Structure	Insulation System	Class H	
	Winding Pitch	2/3 to minimize harmonics effects	
	Number of Poles	4	
	Number of Bearings	Single bearing	
	Winding Leads	12	
	Power Factor	0.8	
	Over Speed Capability (% of	2250 Rpm (150%)	
	Wave Form Distortion	THD(Total Harmonic Distortion)@ No load < 5.0%	
	Telephone Interference	TIF < 2%	
	IP Rating (Protection)	IP23	
AVR	Excitation with auxiliary coil		
	Synchronous, 3 phase, Brushless & Self ventilated		
		1500	1800
Power Switching	3-P/2-P Circuit Breaker, MCB	16A	20A
Temperature	Temperature Rise	125/40 °C	
Control & Voltage Regulator	Control System (Standard)	Self excited	
	Voltage Regulator (AVR)	AS480	
	% Of Voltage Regulation	± 1.0 %	
Motor Starting Capacity@30%	if voltage 230/400V	TBA	
Voltage Dip	if voltage 277/480V	TBA	



METS ENERGY

Standard Controller, M-DCM-317

Control	Auto/Start/Stop Control Emergency Stop Pushbutton/ Alarm Acknowledge Engine Cool Down Timer Warm-up Timer Load Switching Timer Engine Cycle Crank	
Indications	Operating Hours 3 Phase Generator Voltage Sensing & Monitoring Current Protection & Monitoring Power Measurement (kW, kVA, kVAh, kVAh, kVAh, pf) Frequency Monitoring (Hz) Oil Pressure/Coolant Temperature/Fuel Level Monitoring Battery Voltage Monitoring (DC) Alarm Acknowledge	
Warning & Shutdown Alarms	Generator Over/Under Voltage & Frequency Crank Disconnect (Failure to Start) Under/Over Speed Over Current Low oil pressure High Water Temperature Low Fuel Level Low Water Level	
Features	IP 65 (if ordered with gasket) Basic Scheduler 8-35 VDC Supply Digital Inputs(4)- Outputs(4 MPU/ 6 CAN) Event Log (5 shutdowns)	

Optional Accessories

Alternator	AVR (3 phase Sensing) Reactive Droop Winding Temperature Detectors Anti- Condensation Heaters Excitation with auxiliary exciter
Power Switching	4-P Circuit Breaker Special Brands (ABB- MG- Motorized Operation Shunt Trip Under Voltage Trip UVT Residual Current Protection Ground Fault Protection Earthing Kit Surge Arrestor



Optional Accessories^(continues)

Engine	Fuel	<ul style="list-style-type: none"> Micro-Diesel Filter for Micro-Particles Filtration Automatic Fuel Refilling System Fuel Water Separator (2000/5) Mechanical Fuel Level Kit Oversize Fuel Tank Upon Custom Requirements Fuel Tanks-Pipes Heater Optional Built in fuel tank 62 L operation full load (Height will be increased by 100 mm and weight by 20
	Air Inlet	Sy-klone Air Cleaner Installed @ Air Intake System
	Exhaust	<ul style="list-style-type: none"> Muffler: Critical (25→30 dB) Hospital (35→40 dB) Elbow, Flanges, Expanders & Y Adaptors
	Cooling / Heating	<ul style="list-style-type: none"> Radiator with 35 °C or 60 °C Ambient Capability Jacket Water Heater
	Lube	<ul style="list-style-type: none"> Manual Sump Drain Pump Semi-Rotator Hand Pump
	DC System - Starting/Changing	<ul style="list-style-type: none"> Mains Battery Charger 24 V DC-5A Battery Charger 10A-20A on Request Automatic Battery Charger on Request Battery Disconnect Switch DC/AC Current Monitoring (Ammeter) Oversize Battery
	Control Panel	<ul style="list-style-type: none"> DSE 7310/7320/7410/7420-More Inputs & Outputs-Advanced Communications Features; DSE 8610/8710/8810- Load Share Module; Digital & Analogues Inputs Module DSE 2130 (for 7000 Series & Above); Analogue Inputs advanced Module DSE 2131-2133(for 7410 &Above); Digital relay Outputs Module DSE 2157 (for 7000 Series &Above); Analogue Outputs Module DSE 2152 (for 7410 & Above); Local & Remote enunciator Module DSE 2548 (for 7000 Series & Above); Display Modules DSE 2510/2520 (with 7310-7320); Remote Monitoring via: Web Interface (All Series), GSM (for 7000 Series & Above), RS485 (for Dry Contacts Alarm Indication for Customer Use Audible Alarm (Option for 6010/20; Standard for 7000 Series & Above); Voltage Adjust Potentiometer; Speed Adjust Potentiometer;



METS ENERGY S.p.A.

Dimensions & Weights

	Length (mm)	Width (mm)	Height (mm)	Weight Dry (Kg)
Open set (NB)	1500	760	1070	465
SPC Type S	1990	760	1240	690

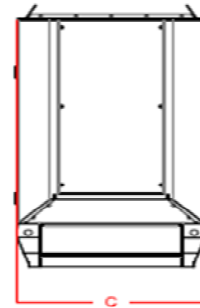
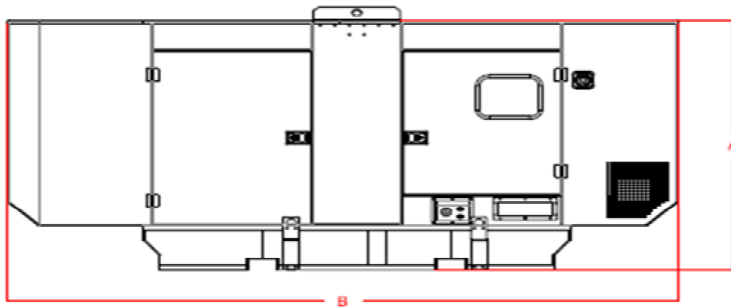
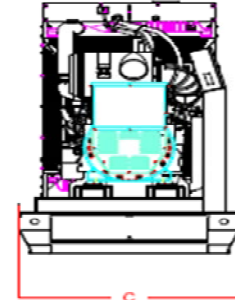
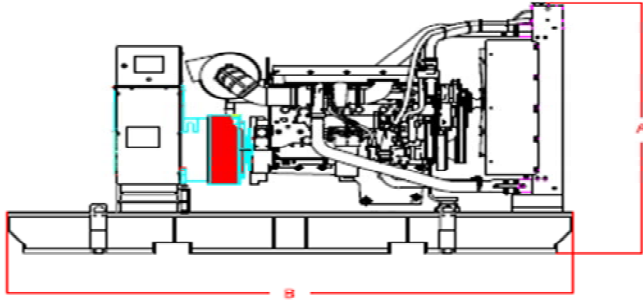

Drawings for illustration purposes only.

WWW.METSENERGY.com